

# CRUSADER CONQUEROR

MODELS 220 - 250

THEMATIC  
ELECTRON  
ENGINE Corporation

CRUSADER MARINE/PACIFIC MARINE,  
7100 East 15 Mile Road, Sterling Heights, Michigan 48077

OWNER'S  
MANUAL

PRICE \$3.00

also Rex Marine 203-866-3303  
(PARTS)

**Personal Information**

Name \_\_\_\_\_

Address \_\_\_\_\_

Telephone \_\_\_\_\_

**Nearest Engine Dealer**

Name TRAVELEX MARINE

Address FREEPORT, N.Y.

Telephone 516-868-1139 (PARTS)

516-868-1193 (SALES)

**Technical Details**

Engine Model 220RS

Spec. Number \_\_\_\_\_

Serial Number 81853

Drive Number \_\_\_\_\_

Propeller Size 2 1/4 8 1/2

F-10 SPARK PLUGS <sup>35 GAP</sup> CHAMPION  
ROTOR - NAPA ECHLIN - ALUMINUM  
POINTS - <sup>20 GAP</sup> ECHLIN CS-9000 DWELL 26-29  
CONDENSER - 25500  
BELTS - Mod AC V-BELT #107  
NAPA - NAPA-1 - Dist Cap  
2D 420A 2D 421A  
4H 421A

Mr. Owner:

We are delighted to welcome you to our growing family of proud Marine Engine owners.

Before starting your first cruise, READ THIS MANUAL CAREFULLY AND COMPLETELY to become better acquainted with your engine.

The descriptions and specifications contained in the booklet were in effect at the time of printing. Thermo Electron Engine Corp., whose policy is one of continued improvement, reserves the right to change specifications or design without notice and without incurring obligation.

See your Engine or Boat Dealer for all your engine needs. He will be glad to assist you.

**THERMO ELECTRON ENGINE**  
CORPORATION  
7100 E. 15 MILE ROAD  
STERLING HEIGHTS, MICHIGAN 48077  
(313) 264-1200

NOTE - BE CERTAIN TO RETURN YOUR WARRANTY REGISTER CARD TO THE ABOVE ADDRESS.

# GENERAL ENGINE SPECIFICATIONS

Type	V8	V8
Rated RPM	4400	4400
Displacement	302	351
Bore/Stroke	4.00/3.00	4.00/3.50
Compression	8.6:1	8.6:1

## TABLE OF CONTENTS

General Engine Specifications .....	1 & 21
Inboard Engine Installation .....	2
Engine Break-In Period .....	6
25 Hour Inspection .....	7
50 & 100 Hour Inspection .....	8
Heat Exchanger Maintenance .....	9
Laying-Up and Fitting-Out Instructions .....	11
Electrical .....	15
Trouble Shooting .....	17
Warranty Services .....	20
Diagnosis and Engine Tune-Up .....	21
Warranty Agreement .....	34

## ENGINE IDENTIFICATION

When ordering spare parts or obtaining information, always give Engine Model, Spec. No., and Serial No. This is found on a metal tag attached to the carb. base.

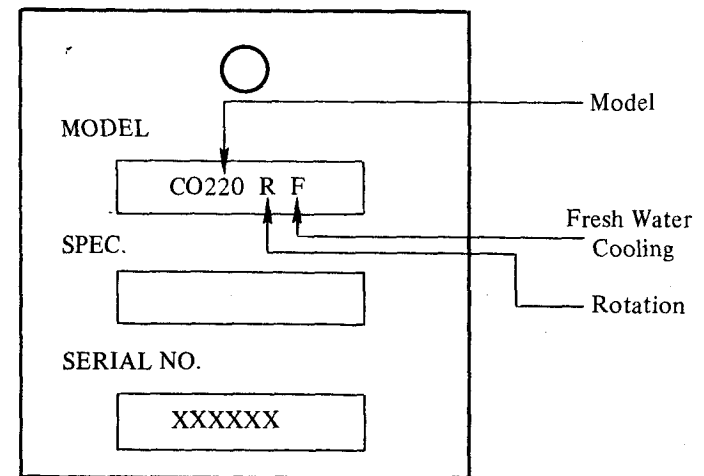

### Code

- R = Right Hand Rotation (Engine)
- L = Left Hand Rotation (Engine)
- F = Fresh Water Cooling
- S = Raw Water Cooling

# INBOARD ENGINE INSTALLATION

(For Inboard/Outboard Installation  
Refer to I/O Installation Manuals)

## GENERAL

Before shipment each engine has been carefully tested, inspected and drained of coolant. In some cases with certain types of installations it may be necessary to add oil to the transmission unit as well as the engine lubricating system.

### A. Engine Compartment

The engine compartment should be well planned giving consideration to accessibility and ventilation. Engines must have air as well as fuel in order to operate efficiently. The battery should be located as close as possible to the starting motor so that the battery leads can be kept short.

### B. Engine Bed

The engine bed should be of the horizontal type and of sufficiently heavy section to insure adequate rigidity to maintain engine alignment. It must be remembered that all of the force used in moving the boat is transferred to the hull through the medium of the engine bed. The standard inboard engine has four support pads which are intended to be used on engine beds arranged for 22-1/2" bolt centers. Use adequate bolts for each support foot. Make certain that there is no interference on the underside of the engine between the oil pan, etc. and the hull

### C. Sea Water Piping

The thru-hull fitting should be one size larger than the water pump inlet fitting and it should be provided with a scoop that will face forward. The connection between the hull and the water pump inlet can be made to suit the convenience of the boat builder. Any hose used in this connection should be of a non-collapsing type. The engine is provided with a thermostat which maintains the engine operating temperature. No recirculating piping is required. Cooling water is discharged through the exhaust line and no extra piping is required.

### D. Exhaust Piping

Each exhaust manifold is provided with exhaust elbows or risers. Exhaust lines must be installed so as to prevent water from getting back into the engine. Exhaust lines must have a definite slope to the transom

of 1/2" to foot of length. If pipe is used in the exhaust line installation, it must be separately supported so that the weight of the pipe is not carried by the exhaust manifold outlets.

### E. Propeller Coupling

The engine end of the propeller shaft must be provided with a keyway. The coupling should have a light drive fit on the shaft and be provided with a key that will fit the sides of the keyway, but not the top of the keyway in the hub of the coupling. A means must be provided to prevent the propeller shaft from being pulled back out of the coupling when the shaft is rotated in reverse direction. This can be accomplished either with spotted set screws or by drilling the shaft through the coupling and inserting a stainless steel pin. In fitting the propeller shaft coupling and inserting a stainless steel pin. In fitting the propeller shaft coupling to the shaft, be careful not to mar the pilot surface of the flange.

*Alignment* – The propeller shaft coupling must be aligned with the reverse gear output coupling flange so they are parallel within .003" The engine mounts must be shimmed or adjusted to correct the alignment. The couplings are aligned by placing a .003" feeler gauge between the couplings at the "Twelve O'Clock" position and bringing the

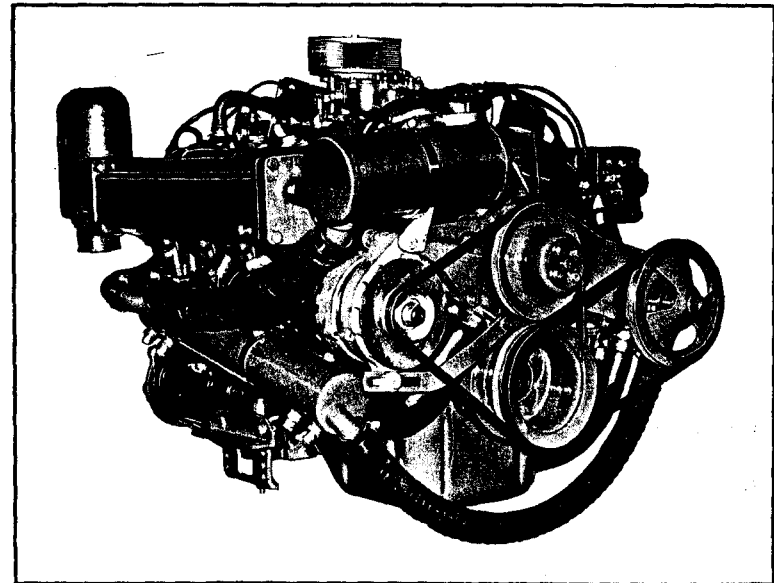

Fig. 1. Freshwater 220/250 Inboard

couplings together so the .003" feeler gauge can be retracted with a slight drag. Holding the shaft in position, insert the .003" feeler gauge at the three, nine, and "six o'clock" position around the couplings. If the alignment is correct, the feeler gauge can be retracted from all positions with the same degree of "feel" (drag). Incorrect vertical alignment can be corrected by inserting shims between the motor mount brackets and the mounting stringers. Incorrect horizontal alignment can be corrected by unlocking and sliding the engine mounting brackets in and out.

The propeller shaft alignment should be rechecked after the boat has been in the water three to four days and at the beginning of each season. The alignment should always be checked after the propeller has struck bottom, or if any unusual vibrations are present.

#### F. Fuel Line

For the fuel line from the tank to the engine we recommend 3/8" min. O.D. tubing adequately secured and provided with a flexible section near the engine to reduce vibration to the line. Fittings for the tubing should conform to coast guard or yacht safety bureau standards. The use of a large capacity fuel filter in this line is recommended. Fuel tanks should be of a size commensurate with the hull requirements and should be anchored securely and vented in such a manner to conform to coast guard regulations. The fuel tank filling arrangements should conform to all safety regulations, and must be outboard. The installation of an approved fuel shut-off valve at the tank is mandatory.

#### NOTE

*Fuel tanks should be installed below the height of the carburetor. It is a recommended practice to include an antisiphon valve in the fuel line.*

#### G. Electrical

All connections should be made through terminals soldered to wires. Do not connect the battery ground cable to aluminum parts of the engine **NEGATIVE GROUND**.

#### H. Propeller

The propeller selected should allow the engine to reach its rated RPM at wide open throttle with a normal load of passengers and gear aboard. (Refer to Page 1 for the rated RPM under General Specifications.)

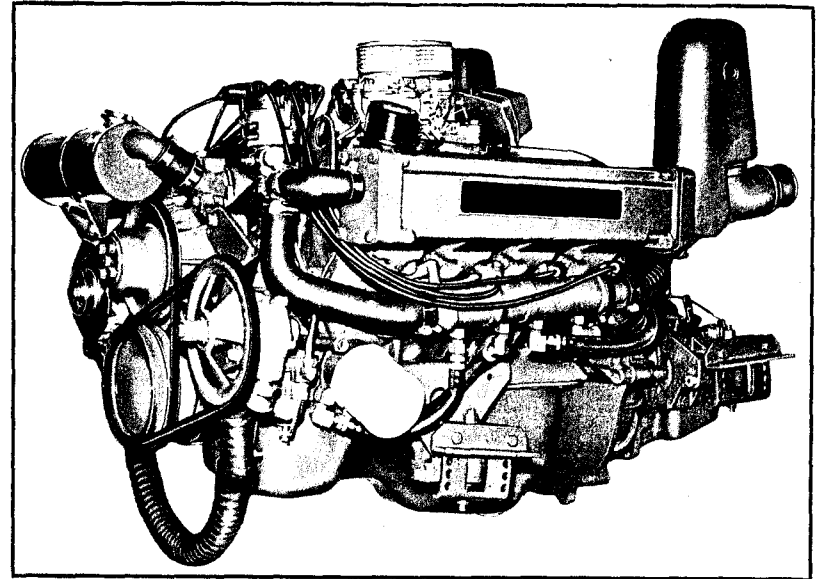

Fig. 2a. 220/250 Inboard

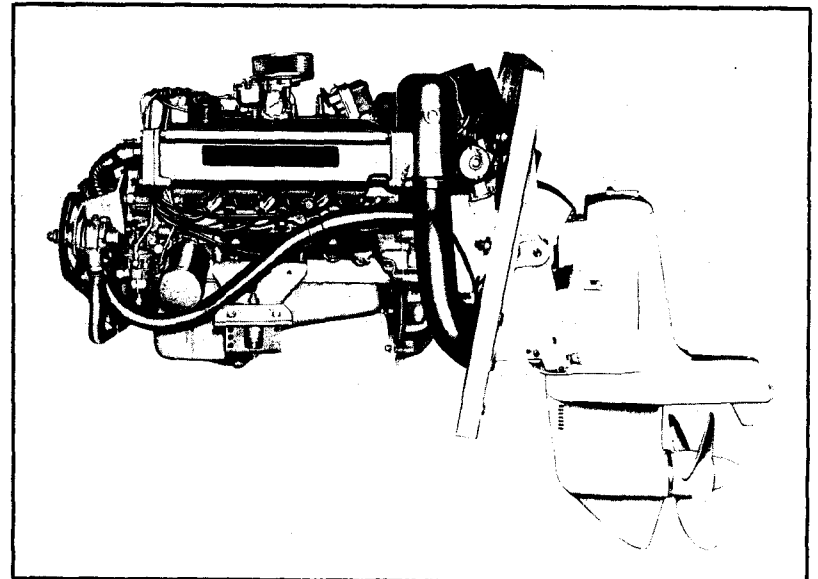

Fig. 2b. 220/250 Inboard/Outboard

The use of a propeller too large to allow the engine to reach its rated RPM will create an overloaded condition that can be detrimental to the engines performance and life. Overloading can cause destructive detonation resulting in holes burnt in pistons and valve; damage of this nature is not covered by warranty.

## RECOMMENDED ENGINE BREAK-IN

*DON'T TAKE CHANCES!*

### NEW BOAT – NEW ENGINE PRE-STARTING RECOMMENDATIONS

1. Open hatches.
2. Start blower fan. (If boat is equipped.)
3. Have fuel tank full.
4. Check all fuel lines for leakage.
5. Check engine oil level – use 10w-30 Heavy Duty Engine Oil meeting manufacturers MS Designation for first 25 hours only.
6. Check transmission oil level – Use type “A.”
7. Check electrical connection. Ground is negative and should be connected to cylinder block.
8. **DON'T ALLOW FLAMES OR SPARKS NEAR BATTERY OPENINGS. EXPLOSIVE GASES PRODUCED DURING NORMAL BATTERY OPERATION MAY BE PRESENT AT THESE OPENINGS AND COULD BE ACCIDENTALLY IGNITED.**
9. Check operation of controls.

### FIRST TIME STARTING RECOMMENDATIONS

1. Fill the carburetor with fuel by cranking the engine with the starter motor.
2. Pump the throttle lever several times to prime intake manifold.
3. Place throttle at 1/4 opening.
4. Turn ignition switch to start position. The engine should start within 20 seconds.
5. Run engine at 700 RPM for warm up.
6. Check oil pressure.
7. Check water outlets (exhaust) for water flow.
8. If oil pressure or water flow is not normal shut off engine and locate problem. (See Trouble Shooting Guide.)
9. Adjust inboard idle speed to 650 RPM in **gear**. Adjust I/O idle speed to 550 RPM maximum in **neutral**.
10. You are now ready to cast off.
11. Check reverse action when you reach open water.

### ENGINE BREAK-IN SCHEDULE

- The first 15 minutes do not operate in excess of 1000 RPM.  
The next 15 minutes do not operate in excess of 1500 RPM.  
\*The next 2 hours do not operate in excess of 2000 RPM.  
\*The next 3 hours do not operate continuously in excess of 2500 RPM.  
\*The next 10 hours do not operate continuously in excess of 3000 RPM.  
\*The next 5 hours do not operate continuously in excess of 4000 RPM.

## RECOMMENDED OWNER PROCEDURE FOR FIRST 25 HOUR INSPECTION CHECK

- Ignition Timing – Use Timing Light (See Specification page.)  
Set Spark Plug Gap – See Engine Specification for Your Specific Engine  
Set Distributor Points – See Engine Specification page 20.  
Tighten Vee Belts  
Align Engine  
Tighten Engine Mounts  
Change Engine Oil – Use 10W-30 MS for cold weather operation & 30W MS for warm weather operation.  
Change Filters – Oil and Fuel

### TRANSMISSIONS

#### A. Inboard Reverse – Transmissions

Engines are fitted with Hydraulic Reverse Gears, except Bobtail engines and engines arranged for Inboard-Outboard Drive.  
Hydraulic Reverse Gears do not usually require field adjustment, but it is important to have the control cable movement in exact harmony with the indexing of the reverse gear control lever positions, Forward, Neutral and Reverse. Some adjustment is available at the end of the control cable to assist in obtaining the proper indexing. Never remove the reverse gear indexing mechanism.

---

\*Operate infrequently for short periods of 2 to 3 minutes duration at higher RPM. Do not operate steadily at the prescribed RPM for running during break-in period. Reduce the throttle occasionally and then come back gradually to that portion of the program you are following. At the end of 25 hours operation make the 25 hour check. (See above.) Observe engine temperature indicator frequently.

**Reverse Gear Lubrication.** Use Type "A" suffix "A" hydraulic transmission fluid. **DO NOT USE ENGINE OIL** in this system. Fill the transmission to the full mark on the reverse gear dipstick, then start the engine and operate at slow speed for a short time to fill all the hydraulic fluid lines and the cooler. Stop the engine and check the fluid level. Add fluid to bring to full mark on dipstick.

Shifting from one position to another should be done at reduced throttle setting. Do not shift above 1000 RPM while maneuvering.

## B. Inboard-Outboard Drives

**Inboard-Outboard Drive.** The shift mechanism for Inboard-Outboard drives is contained in the drive unit. Shifting should be done at reduced engine speed not to exceed 550 RPM. Refer to I/O manual for lubrication specifications.

It is important that the shift control be adjusted to give accurate detent positions in forward, neutral and reverse.

## SCHEDULE OF MAINTENANCE

### Daily

1. Ventilate Engine Compartment thoroughly before starting engine, by operating engine compartment blower or removing engine box or hatch.
2. Before Starting The Engine, check the engine crankcase and transmission oil levels.

As soon as the engine is started, check the water flow at the exhaust lines. Observe the oil pressure light and note the action of the ammeter.

### Each 50 Hours

1. To change Oil, operate the engine until it is thoroughly warm. Warm oil flows faster and impurities will be carried out with the old oil. Insert the oil pump suction tube. This tube must be of sufficient length to reach the bottom of oil pan. Remove the old oil from the engine. **Change filter element and refill with fresh oil. Check level again after 3 or 4 minutes running.**
2. Flame Arrester screens should be inspected to be sure that they are free from excessive oil or lint. **If the motor box is lined with fiberglass, this inspection should be made every 25 hours. Restriction of the air passages results in an improper fuel mixture and inefficient operation.**
3. Check The Battery water level and maintain the electrolyte at 3/8 inch above the plates. Proper fluid gravity is 1.250-1.275 for a fully charged battery. Inspect battery terminal for corrosion.

4. Inspect And Clean fuel line filters. Also check for loose connections, cracked fittings, etc.
5. Check All Water Lines for leaks or hose deterioration.
6. Check Wiring Terminals for loose or corroded connections.

### Each 100 Hours

Adjust breaker points in distributor. Check spark plugs. Replace cracked or doubtful spark plugs with factory-recommended plugs. If the spark plug is fouled, determine the reason for fouling, and correct it. See page 27 for spark plug diagnosis. Tighten mounting bolts and check the engine coupling for proper alignment. The alternator drive belt deflection across the longest span should be a maximum of 1/2"; the sea water pump belt deflection should be a maximum of 1/8". See diagram and chart on page 10. Check the ignition timing with a power timing light.

## HEAT EXCHANGER MAINTENANCE

*(Fresh-Water Cooling)*

Engines equipped with fresh-water cooling should operate between 160°F. and 180°F. Permanent type ethylene glycol antifreeze should be used in the heat exchanger for cold weather use, or year round, **but you must drain the sea water circuit to protect the oil cooler, sea water pump, exhaust manifold, outlet elbow, and sea water sections of heat exchanger from freezing.**

### FILLING THE HEAT EXCHANGER

Remove the filler cap. Check all hose connections and draincocks for tightness. Fill the system with clean fresh water.

**IF SYSTEM IS OVER FILLED, IT WILL DISCHARGE EXCESS WATER THROUGH OVERFLOW TUBE. DO NOT REMOVE FILLER CAP UNTIL ENGINE IS COOL.** Water level should be approximately one inch below filler neck when engine is cool.

### CLEANING THE HEAT EXCHANGER

Cleaning of the heat exchanger is not recommended unless an overheating complaint can be traced to a clogged heat exchanger.

1. Drain both the raw (sea) water and fresh-water (coolant) systems.
2. Remove all hoses connected to the end tanks of the exchanger unit.
3. Loosen the retaining clamps and remove the heat exchanger assembly.

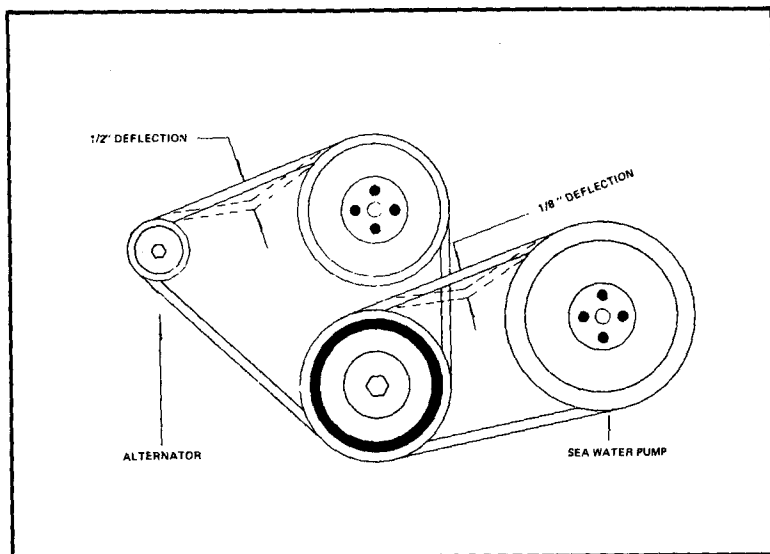

Fig. 3. Belt Adjustment

**MAINTENANCE CHART**  
**ITEMS TO BE CHECKED OR LUBRICATED**

	Daily	Each 25 Hrs.	Each 50 Hrs.	Each 100 Hrs.	Each Season
Breather Cap . . . . .			Clean		Clean,
Breaker Valve . . . . .					replace
Control Rods . . . . .		Check & lubricate	non petroleum		graphite base
Cooling System . . . . .	Check				
Distributor Lube Fitting . . . . .			Lubricate		
Distributor Points . . . . .			Check/one drop of oil on		
			point felt		
Distributor Cap & Rotor . . . . .			Check/one drop of oil on		
			felt under Rotor		
Engine Oil Level . . . . .	Check				
Engine Oil-Drain . . . . .			Change		Change
Engine Oil-Filter . . . . .			Change		Change
Flame Arrestor . . . . .		Clean			Clean
Fuel-Lines . . . . .	Check				Check
Fuel-Level in Tank . . . . .	Check				
Inboard-Outboard Drive . . . . .					
See Inboard-Outboard manual					
Rev. & Red. Gear- Fluid Level . . . . .	Check				Change
Spark Plug . . . . .			Check	Change	Change
			Gap		
			Check		
Vee Belt Tension . . . . .					
Water-Battery . . . . .	Check				
Water-Lines . . . . .			Check		Check

4. Reverse-flush the heat exchanger assembly with the aid of a garden hose.
5. Reinstall on engine in reverse order as removed.
6. Fill with coolant and test run. (See filling instructions.)

## LAYING-UP INSTRUCTIONS

### A. CHANGE OIL

Operate the engine long enough to bring engine to operating temperature. Remove the old oil using a suction pump provided with a tube, which can be inserted into the dipstick tube. The suction tube must be long enough to reach the bottom of the oil pan. Replace the oil with a good grade of heavy-duty engine oil per our specification. **ADD ONE CAN OF CRANKCASE OIL SUPPLEMENT PART NO. 1003677 (or equivalent).** A new oil filter should be installed at this time.

### B. FOGGING ENGINE

Disconnect fuel line at fuel pump, **MAKING SURE FUEL SUPPLY IS SHUT OFF AT FUEL TANK.** Hook up a temporary fuel line from the pump to a one-quart container with a fifty-fifty mixture of fuel and **FUEL CONDITIONER AND VALVE LUBRICANT PART NO. 1003676 (or equivalent).** Start engine and remove flame arrestor, set idle speed at 900 to 1000 RPM and slowly pour **RUST PREVENTATIVE OIL PART NO. 1003678 (or equivalent),** through primary side of carburetor until heavy oil smoke is obtained at the exhaust outlet (S), watching fuel supply in container. Just before engine starts to die, pour balance of rust preventative oil in carburetor to stall out engine. Shut off ignition switch and do not attempt to turn engine over until ready to recommission. Replace flame arrestor and seal off with masking tape.

### C. CLOSED COOLING SYSTEM

On fresh water models with antifreeze in the cooling system (this should be of ethylene glycol type), should be tested to insure sufficient protection. This test must be made prior to Step No. 2, while engine is hot.

On fresh water models without anti-freeze in the system, the system must be thoroughly drained by use of petcocks on each side of the block. The filler cap on the expansion tank must be removed and the drains on heat exchanger must be removed to drain the system.

The sea-water side of the system must be drained by removing the drains on the heat exchanger and oil coolers. Remove hose from raw



water pump at front of heat exchanger and open petcocks on exhaust outlets. The hoses and drains should then be replaced after draining and two quarts of anti-freeze put into the block. This is accomplished by removing the temperature sending unit and pouring anti-freeze through the hole. The raw water pump must be drained by loosening the rear cover. On inboard-outboard models the water pick-up hose must be removed from the pump inlet and thoroughly drained.

#### D. OPEN COOLING SYSTEM

On raw water models there are two petcocks, one on either side of the block, which must be drained. To insure complete drainage of the block, remove the temperature sending unit to break the vacuum in the system. The hose between the raw water pump and the lower tee must be removed. The manifolds, risers, and I/O pick-up hose are drained in the same manner as the fresh water models mentioned above. On all models so equipped the engine and transmission oil coolers must be drained by either removing the drain plug on the bottom or removing the hoses. All petcocks and plugs should be replaced and then pour one quart of anti-freeze through the temperature sending unit hole to insure protection against any water pockets. Remove exhaust hoses at risers and seal off risers with an oily rag.

#### E. ELECTRICAL SYSTEM

Remove the battery and have it maintained over the storage period. Do not loosen the distributor cap.

#### F. SHAFT

Disconnect propeller coupling.

#### G. GENERAL

Remove from the engine compartment any items which might hold moisture, such as ropes, life preservers, mops, rags, cushions, and pillows.

#### H. PAINT

Clean and touch up the engine paint.

## FITTING-OUT AFTER STORAGE

#### A. ENGINE CLEANING

Close all drains on the engine and inspect all hoses for possible deterioration as well as tightness.

#### B. WIRING

Examine all wire terminals and clean if there is any evidence of corrosion.

#### C. SPARK PLUGS

Examine spark plug wires. If these show signs of cracks in the insulation, they should be replaced. Remove the spark plugs and leave them out of the engine until you complete the next procedure.

#### D. VALVES

Remove the valve covers and individually check that each valve is free by depressing it. In a modern marine engine there is a very small clearance between the valve guide bore and the valve stem so that even a slight rust spot can cause a valve to stick, resulting in a bent push rod when the engine is cranked. If a valve is found to be stuck or sluggish, it can usually be freed by putting penetrating oil directly on the valve stem so it can run down into the valve guide. It is a good idea to spray all valve stems using a product such as FUEL CONDITIONER & VALVE LUBRICANT PART NO. 1003676 (or equivalent).

Turn engine engaging starter intermittently to make at least two complete revolutions. Observe the valve action when this is done to be sure the valves are free. If the valve action is in order, you can replace the spark plugs and the valve covers. A new set of spark plugs of the correct type is a worthwhile investment. See Onboard Spare Parts Kit.

#### E. DISTRIBUTOR

Remove the distributor cap and rotor. Check the breaker points and gap. If the breaker point spring shows a rust spot, replace the points and reset the gap. Remove any moisture which may have accumulated inside the distributor and reinstall the rotor and the cap.

#### F. FUEL FILTERS AND SCREENS

Clean all filters and screens in the fuel line. The fuel filter element should be replaced once a season. Examine all flame arrestor screens and remove all traces of dirt or lint, including those on the distributor.

## G. BATTERY AND CABLE

Install a fully charged battery after cleaning the terminal posts and cable ends. When the cables are attached (negative ground), coat the cable connections with grease. **DO NOT REVERSE OR ARC THE BATTERY CABLES** when installing, as this will damage the alternator and /or regulator.

## H. OIL LEVEL

Check the engine oil level and also the level of the transmission fluid if the engine is fitted with a reverse gear. The correct operating oil level indicated by the dipstick will vary from one installation to another depending on the angle that the engine is installed on.

## I. FUEL TANK, LINES AND CONNECTIONS

Check the fuel tank and fill if necessary. Open all valves in the fuel line and check all connections for leakage.

## J. GENERAL ENGINE CHECKS

Make a final check of the engine for loose nuts or screws. If the boat is provided with a sea cock for the water cooling system, be sure this valve is open. Vent the engine compartment to remove all trace of vapors. Unplug exhaust lines.

## K. ENGINE OPERATIONAL CHECKS

The boat should have been stored with the propeller shaft disconnected, but if not, the propeller shaft coupling should be disconnected when the boat is first put in the water. Check the engine shaft alignment after the hull has soaked up and with the normal running gear on board. Upon starting the engine, verify the function of the oil pressure, temperature and ammeter. The water pump should be primed to insure a flow of water promptly. If the lubricating oil was not changed prior to the storage period, the engine should be kept in operation until it is warm, then the oil should be changed. Always replace the oil filter when the oil is changed.

## ELECTRICAL

### PRECAUTIONS TO BE OBSERVED WHEN INSTALLING, TESTING OR SERVICING THE ALTERNATOR

#### A. REVERSED BATTERY CONNECTIONS WILL DAMAGE THE RECTIFIERS, WIRING OR OTHER COMPONENTS OF THE CHARGING SYSTEM.

Battery polarity should be checked with voltmeter before connections are made to be sure that the connections correspond to the systems ground polarity. System is negative ground.

#### B. IF BOOSTER BATTERIES ARE USED FOR STARTING THEY MUST BE CONNECTED PROPERLY TO PREVENT DAMAGE TO THE CHARGING SYSTEM COMPONENTS.

The negative (-) cable from the booster battery must be connected to the negative terminal of the battery in the boat and the positive (+) booster cable to the positive terminal.

#### C. CARE SHOULD BE USED WHEN CONNECTING A "CHARGER."

The "Charger" should not be used as a booster for starting the engine. Disconnect both cables when a charger is used.

#### D. THE FIELD CIRCUIT MUST NEVER BE GROUNDED BETWEEN THE ALTERNATOR AND THE REGULATOR.

Grounding of the field terminal at either the alternator or the regulator will damage the regulator.

#### E. GROUNDING OF THE ALTERNATOR OUTPUT TERMINAL WILL SERIOUSLY DAMAGE THE ALTERNATOR AND/OR CIRCUIT AND COMPONENTS.

Disconnect the battery ground cable before removing the alternator or its connectors.

**F. DO NOT ATTEMPT TO POLARIZE THE ALTERNATOR.**

No polarization is required. Any attempt to do so will result in damage to the alternator, regulator, or circuits.

**FIRING ORDER**

Engine	Rotation	Order
CO220	LEFT (Counterclockwise)	13726548
CO250	RIGHT (Clockwise)	18456273

NOTE. Rotation is determined by standing at rear of engine looking forward. Reference is made to direction of crankshaft rotation, not to propeller shaft rotation

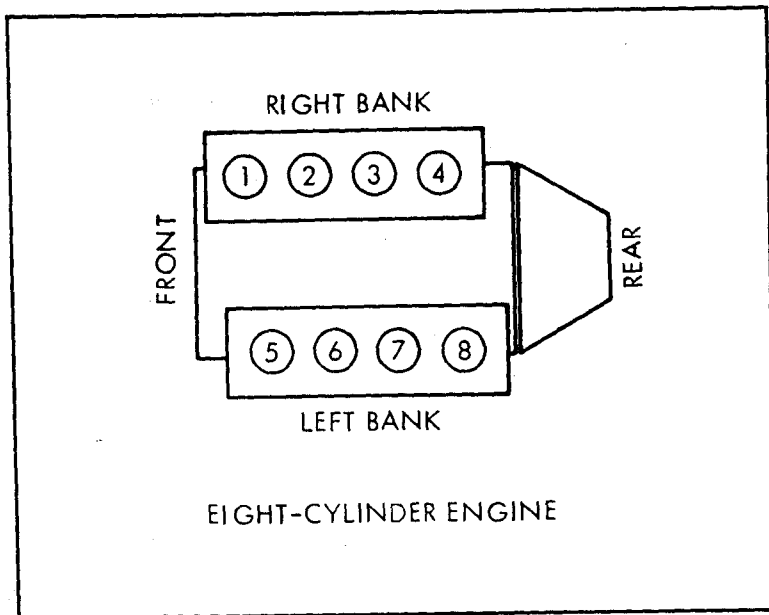

Fig. 4. Cylinder Arrangement

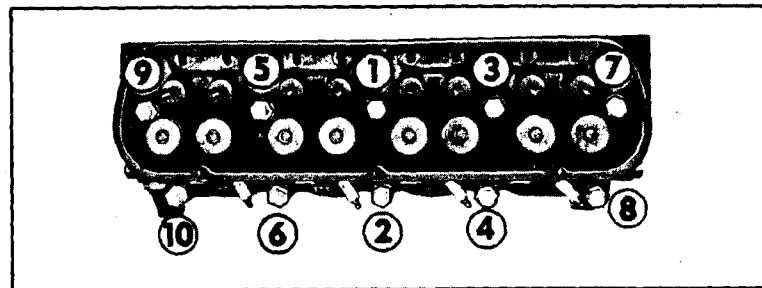

Fig. 5. Cylinder Head Bolt Tightening Sequence

**REPLACING CYLINDER HEAD**

If a cylinder head is removed observe the following instructions concerning installation of same.

1. Cylinder head – Cylinder block and gasket surface must be CLEAN.
2. Dip cylinder head bolts in oil or grease.
3. Long bolts are used on top and short bolts are used in bottom row of holes.
4. See illustration for sequence of tightening which must be done in three progressive steps.
  - a. Tighten in sequence to 50 ft. lbs.
  - b. Tighten in sequence to 60 ft. lbs.
  - c. Finally tighten in sequence to 70 ft. lbs.
5. After cylinder head bolts have been torqued to specifications operate the engine to operating temperature (20 minutes at idle) and retorqued following the above sequence.

**TROUBLE SHOOTING**

**GENERAL**

Engine performance complaints usually fall under one of the basic headings listed in the Trouble Shooting Guide on page 18. When a particular trouble cannot be traced, a definite cause may be determined by a simple check. The possible items that could be at fault are listed in the order of their probable occurrence.

Check the items in the order listed.

Malfunction	Probable Causes	Corrective Action
1. Engine will not crank.	<p>a. Hydrostatic lock.</p> <p>b. Starting system malfunctioning.</p> <ol style="list-style-type: none"> <li>If engine is fitted with a safety switch, clutch control must be in neutral position to complete circuit.</li> <li>Dead battery.</li> <li>Loose wire in starting circuits.</li> <li>Defective solenoid</li> <li>Insufficient ground at starting motor to mounting.</li> <li>Insufficient size battery cable.</li> </ol>	<p>a. Remove plugs and crank engine. If engine cranks, it indicates that water is getting into the cylinders from the exhaust system or from a gasket leak. If water gets into the engine through the exhaust line, this indicates improper draining of exhaust system. Exhaust risers are available from our Parts Department to assist in obtaining proper drainage.</p> <p>b. Locate the correct malfunction.</p> <ol style="list-style-type: none"> <li>Check position of clutch control lever.</li> <li>Recharge or replace battery.</li> <li>Tighten all wiring connections.</li> <li>Replace solenoid.</li> <li>Remove paint from starting motor mounting flange.</li> <li>Check and replace with an adequate size cable.</li> </ol>
2. Engine cranks normally but will not start.	<p>a. No fuel.</p> <p>b. No sparks or weak spark at plugs.</p> <ol style="list-style-type: none"> <li>Distributor cap brush broken.</li> <li>Good spark at coil high-tension lead.</li> <li>No spark or weak spark at the coil high-tension lead.</li> </ol> <p>c. Good spark at the plugs.</p> <ol style="list-style-type: none"> <li>Bad plugs.</li> <li>Engine flooded.</li> <li>Sticking choke plate.</li> <li>Fuel not reaching carburetor (assuming all shutoff valves are open.)</li> </ol>	<p>a. Open shut-off valve, clean strainers and check fuel level.</p> <p>b. Ignition system malfunction</p> <ol style="list-style-type: none"> <li>Replace brush.</li> <li>Replace distributor cap or rotor.</li> <li>Replace high-tension lead or coil.</li> </ol> <p>c. Check plugs and fuel system.</p> <ol style="list-style-type: none"> <li>Replace with recommended plugs.</li> <li>On hot engines, operate throttle fully.</li> <li>Check thermostatic spring housing adjustment.</li> <li>Check the following. Fuel pump, fuel pump filter, carburetor fuel filter and fuel tank line for cracked flanges or restricted fittings.</li> </ol>
3. Engine starts, but fails to keep running.	<p>a. Idle fuel mixture improperly adjusted.</p> <p>b. Choke not operating properly.</p> <p>c. Float setting incorrect.</p> <p>d. Fuel pump defective.</p> <p>e. Dirt of water in fuel lines, fuel filter or carburetor.</p>	<p>a. Adjust idle needle(s) to proper setting.</p> <p>b. Check and repair as required.</p> <p>c. Adjust float setting. See Service Manual.</p> <p>d. Replace or repair fuel pump.</p> <p>e. Check and clear all components of obstructions.</p>

Malfunction	Probable Causes	Corrective Action
4. Engine runs but misses.	<p>a. Bad spark plug.</p> <p>b. Crossed spark plug wires.</p> <p>c. Spark plug wires not engaged securely in distributor cap or at plug.</p> <p>d. Restricted fuel filter.</p> <p>e. Cracked spark plug wires.</p> <p>f. Cracked distributor cap.</p> <p>g. Burned breaker points</p> <p>h. Exhaust system restricted.</p> <p>i. Carburetor float setting incorrect.</p> <p>j. Valve sticking.</p>	<p>a. Replace with recommended plugs.</p> <p>b. Make certain all spark plug wires are connected to the proper plugs. See page 27.</p> <p>c. Check and make certain that all connections are secure.</p> <p>d. Clean or replace fuel filter.</p> <p>e. Replace as required.</p> <p>f. Replace.</p> <p>g. Replace.</p> <p>h. Check and remove restrictions.</p> <p>i. Reset float setting. See Service Manual.</p> <p>j. Free valve. See page 13.</p>
5. Rough engine idle.	<p>a. Engine idle speed set too low.</p> <p>b. Idle fuel mixture needle(s) not properly adjusted.</p> <p>c. Float setting incorrect.</p> <p>d. Secondary throttle plate(s) not closing (4-barrel carburetor only).</p> <p>e. Incorrect engine timing.</p> <p>f. Bad plugs.</p> <p>g. Points worn or misadjusted.</p>	<p>a. Reset engine idle. See page 22.</p> <p>b. Adjust idle fuel mixture needles. See Service Manual.</p> <p>c. Adjust float setting. See Service Manual.</p> <p>d. Check and adjust or repair as required.</p> <p>e. Time engine. Make certain plug wires are not crossed.</p> <p>f. Check and replace as required.</p> <p>g. Adjust points.</p>
6. Poor acceleration.	<p>a. Accelerating pump</p> <p>b. Incorrect ignition timing.</p> <p>c. Bad or improperly set spark plugs or breaker points.</p> <p>d. Inoperative accelerating pump inlet or discharge ball check.</p> <p>e. Float setting incorrect.</p> <p>f. Restricted fuel filters.</p> <p>g. Dirty flame arrester screen.</p>	<p>a. Replace</p> <p>b. Time engine.</p> <p>c. Clean and reset or replace as required.</p> <p>d. Replace ball check or spring.</p> <p>e. Adjust float setting. See Service Manual.</p> <p>f. Clean or replace.</p> <p>g. Clean or replace as required.</p>
7. Excessive fuel consumption.	<p>a. Dirty flame arrester screen.</p> <p>b. Distributor breaker points or spark plugs bad or set improperly.</p> <p>c. Ignition timing improperly adjusted.</p> <p>d. Choke not properly adjusted.</p> <p>e. Float level too high.</p>	<p>a. Clean or replace as required.</p> <p>b. Clean and set or replace breaker points and spark plugs.</p> <p>c. Time engine.</p> <p>d. Adjust as required.</p> <p>e. Reset float level as required. See Service Manual.</p>

Malfunction	Probable Causes	Corrective Action
8. Engine overheats.	a. Bad sending or receiving unit. b. Loose wiring connections at sending or receiving unit. c. Worn or broken impeller in sea water pump. d. Clogged oil cooler. e. Exhaust lines plugged. f. Late ignition timing. g. Choke valve stuck closed. h. Collapsed water pump suction hose. i. Loose or worn belts. j. Restricted intake scoop.	a. Replace unit(s). b. Tighten all connections. c. Replace impeller. d. Remove restrictions. e. Remove restrictions. f. Time engine. g. Free action of choke valve. h. Install new hose. i. Adjust/replace. j. Clean.

### WARRANTY SERVICE

In the event you require warranty service:

1. Contact your nearest authorized Marine Dealer.
2. Have the following information available:
  - a. Identification card
  - b. Engine model, spec, & serial number
  - c. I/O drive unit serial number
  - d. Owner's name and address
  - e. Date put into service
  - f. Hours in service
  - g. Manufacturer of boat
  - h. Location of boat
  - i. Nature of specific trouble
3. To avoid misunderstanding we list certain items that do not come under warranty.
  - a. Corrective measures in equipment not furnished by Thermo Electron Engine Corp.
  - b. Corrective measure in fuel, exhaust, wiring, or control systems in boat.
  - c. Failures resulting from use of improper fuel.
  - d. Failures from overspeeding the engine.
  - e. Ignition points, condenser, caps, rotor or wires.
  - f. Spark plugs.
  - g. Engine or gear oil.
  - h. Filters, paint, rags, etc.

### GENERAL ENGINE SPECIFICATIONS

	220 H.P.	250 H.P.
Type and Number of Cylinders	V8	V8
Bore	4.00"	4.00"
Stroke	3.00"	3.50"
C.I.D.	302	351
Compression Ratio	8.6:1	8.6:1
Fuel Requirements	90 Octane (Research Method)	90 Octane (Research Method)
Basic Ignition Timing	12° @ Idle	12° @ Idle
Spark Plugs	Autolite BF32 Champion UF9Y	Autolite BF42 Champion UF11Y
Spark Plug Gap	.035	.035
Distributor Point Gap	.020"	.020"
Distributor Cam Dwell	26°-29°	26°-29°
Fuel Pump, PSI	4-6 lbs @ 500 RPM	4-6 lbs @ 500 RPM
Engine Oil Recommendation		
Inboard	10/30W (MS)	10/30W (MS)
Transmission Fluid	Type "A"	Type "A"
Electrical Ground	Negative	Negative
Valve Clearance	See Note A	See Note A
Idle Speed	See Note B	See Note B

NOTE A — These engines are equipped with hydraulic valve lifters — See Factory Authorized Dealer for service.

NOTE B — Idle speed on all engines used with I/O 550 RPM in neutral. Idle speed on all engines used with Inboard 650 RPM in gear.

### DIAGNOSIS AND ENGINE TUNE-UP

In cases of poor performance that do not appear to be caused by an ignition or carburetor fault, a compression check should be performed.

### A. Compression Test

1. Be sure the crankcase oil is at proper level and the battery is fully charged. Operate the engine for a minimum of 20-30 minutes at 1000-1200 R.P.M., or until the engine has reached proper operating temperature. Turn the ignition switch off, then remove all spark plugs. Remove the coil high tension lead from the distributor cap and ground it on the engine block.

2. Open the throttle to wide open throttle position and make certain the choke valve in the carburetor air horn is fully open.

3. Install a compression gauge in number one cylinder.

4. Crank the engine with the starter motor the number of compression strokes required to obtain maximum reading on the compression gauge (usually 5-6 strokes are required.)

5. Repeat the test on each cylinder, cranking the engine the same number of times for each cylinder as was required to obtain the highest reading on the number one cylinder.

#### Test Conclusions

A uniform variation of  $\pm 20$  p.s.i. from 130-170 p.s.i. is permissible. However, the compression of all cylinders should be uniform within 10 p.s.i. A reading of more than the allowable tolerance above normal indicates excessive carbon deposits in the cylinders. A reading below the allowable tolerance (below normal) indicates leakage at the cylinder gasket, piston rings or valves.

A low, even compression in two adjacent cylinders indicates a cylinder head gasket leak. This should be checked before condemning the rings or valves.

To determine whether the rings or the valves are at fault, squirt approximately one tablespoon of engine oil into the combustion chamber through the spark plug hole. Crank the engine and repeat the compression test. The oil will temporarily seal leakage past the rings. If approximately the same reading is obtained, the rings are satisfactory but the valves are leaking. If the compression has increased 10 pounds or more over the original reading, there is leakage past the rings.

During a compression test, if the pressure fails to climb steadily and remains the same during the first two successive strokes, but climbs higher on the succeeding strokes, or fails to climb during the entire test, it indicates a sticking valve.

### B. Manifold Vacuum Test

A manifold vacuum test aids in determining the condition of an engine and also in helping to locate the cause of poor engine perform-

ance. Manifold vacuum tests should be performed in the following steps:

1. Operate the engine for a minimum of 20-30 minutes at 1000-1200 R.P.M., to bring to operating temperature.
2. Install an accurate, sensitive vacuum gauge in the intake manifold fitting.
3. Operate the engine at the recommended idle R.P.M. with the transmission in neutral position.
4. Check the vacuum reading on the gauge; this reading should be 18-21". If a lower or erratic reading is obtained, see authorized dealer.

### C. Crankcase Vent Valve Test and Service

A malfunctioning positive crankcase ventilating valve may cause the engine to lope at idle. Do not attempt to compensate for this idle

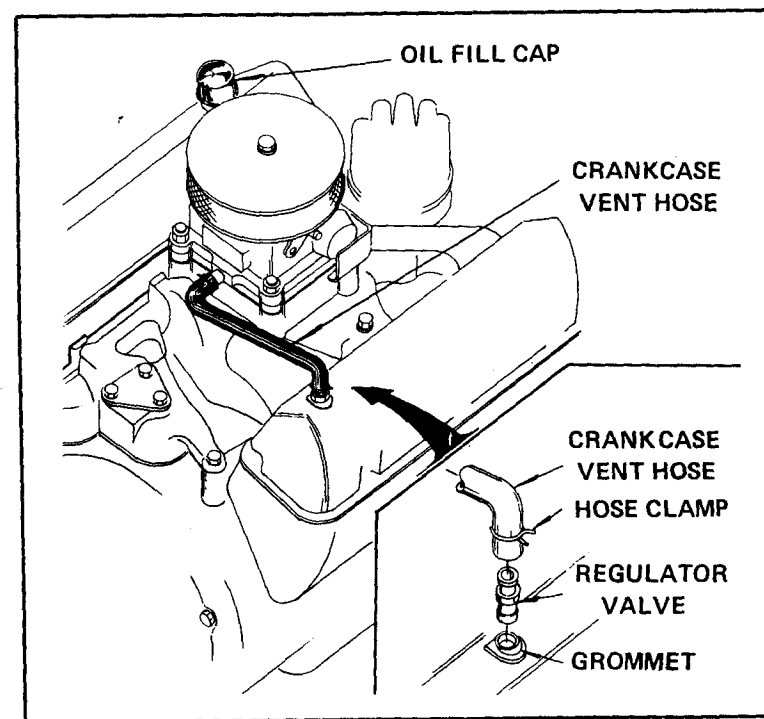

Fig. 6. Crankcase Ventilation System

condition by disconnecting the vent hose and making carburetor adjustments. The removal of the crankcase vent valve from the engine will adversely offset the fuel economy and engine ventilation with resultant shortening of engine life. This valve is non-servicable and should be replaced each season.

The oil cap should be cleaned when the oil filter is changed (approximately every 50 hours of operation) or once a season, whichever occurs first.

The fill caps should be washed in mineral solvent, but should not be dried with compressed air, as a jet of compressed air can separate the wire mesh in the cap.

#### D. Ignition System

Spark Plugs should be removed, cleaned or replaced with new ones every 100-150 hours of operation. Spark plugs for these engines do not require gaskets, as they are of the tapered-seat type.

Examine the firing ends of the spark plugs. Used spark plugs can reflect many things about the condition and state of tune of an engine. Refer to Fig. 7 for diagnosis of possible spark plug malfunctions.

When replacing or rerouting high tension spark plug leads, route them in a manner which will discourage "cross-fire" between plug leads. Be certain that plug leads to number seven and eight cylinders are separated.

##### *Distributors*

Distributors very seldom require extensive repairs, but should be periodically checked for wear and deterioration of the ignition points, rotor and cap.

Faulty ignition points will usually appear dark grey or blue-black in color. Faulty points should be replaced and not filed. Filing will remove the tungsten coating and allow the points to burn rapidly and is, therefore, not recommended. Oil or crankcase vapors, which work into the distributor and deposit on the points, will cause rapid point burning. This is easy to detect, since the oil produces a smudgy ring under the points. To overcome this, check for clogged crankcase ventilation system, worn distributor shaft, or over-oiling of the distributor shaft. The ignition system is designed to operate on 6-9 volts and if the resistor connected between the ignition switch and the + terminal of the coil has been removed or jumped, the points can burn rapidly from the full 12 volt battery power. A faulty alternator or regulator, which is overcharging, will also cause a rapid deterioration of the ignition points.







CONDITION	IDENTIFICATION	CAUSED BY
 OIL FOULING	Wet, sludgy deposits.	Excessive oil entering combustion chamber through worn rings and pistons, excessive clearance between valve guides and stems, or worn or loose bearings.
 GAS FOULING	Dry, black, fluffy deposits.	Incomplete combustion caused by too rich a fuel-air mixture or by a defective coil, breaker points or ignition cable.
 BURNED OR OVERHEATING	White, burned, or blistered insulator nose and eroded electrodes.	Inefficient engine cooling, or engine overheating caused by improper ignition timing, wrong type of fuel, loose spark plugs, or too hot a plug.
 NORMAL CONDITIONS	Rusty brown to grayish-tan powder deposit and minor electrode erosion.	Regular or unleaded gasoline.
 NORMAL CONDITIONS	White, powdery deposits.	Highly leaded gasolines
 CARBON FOULING	Hard baked on black carbon.	Too cold a plug.

Fig. 7. Spark Plug Diagnosis

When installing new points, be certain that the movable contact point is in true alignment with the stationary point. The point alignment can be corrected by bending the stationary point (never bend the movable contact arm). (See Fig. 8.)

Set the point gap with a clean feeler gauge to .020". If a dwell meter is used to check the gap, be certain it indicates 26°-29°. Remember, as the gap increases the dwell decreases, shortening the saturation time of the coil and causing poor performance.

The distributor cap and rotor should be checked for hair line cracks and deterioration of the contacts. If there is presence of dirt and oil film on the inside of the cap wash it in soap and water and thoroughly dry.

Lubricate the distributor cam with a light film of special purpose high melting point grease, (included in ONBOARD SPARE PARTS KIT.) One drop of engine oil should be put in the Distributor felt under rotor every 50 hours of operation. If the distributor is fitted with a mechanical tachometer drive adaptor, lubricate the grease fitting on the side of the distributor housing with the use of a hand operated grease gun. (Stop at the slightest back pressure.) At the beginning of each season, remove the distributor tachometer drive mechanism by backing off the hex with a suitable wrench. Remove the gear and inspect for wear. Cleanse all parts, pack with lubriplate and reinstall.

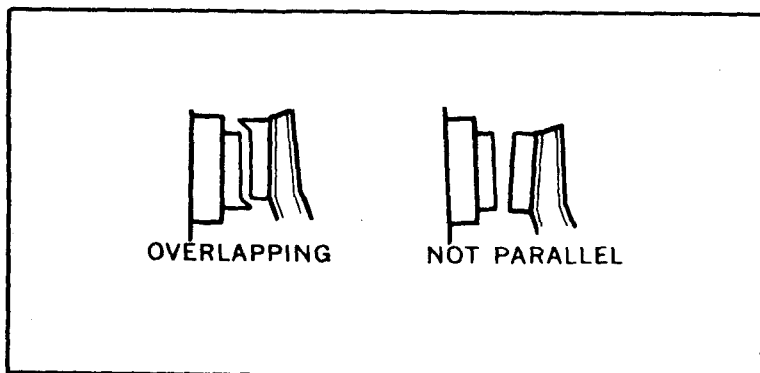

Fig. 8. Example - Poor Alignment

## FIRING ORDER

Engine	Rotation	Order
CO220	LEFT (Counterclockwise)	13726548
CO250	RIGHT (Clockwise)	18456273

*NOTE: Rotation is determined by standing at rear of engine looking forward. Reference is made to direction of crankshaft rotation, not to propeller shaft rotation.*

### Ignition Timing

The setting should be made with the use of a power timing light with the engine operating at a constant R.P.M. in the following steps, refer to page 21 for specifications.

1. Operate the engine 15-20 minutes to bring the operating temperature up to normal.
2. Attach a strobe light (power timing light) to number one cylinder high tension lead.
3. The throttle should be set to give a steady 550 or 600 R.P.M.
4. Direct the light beam from the timing light onto the timing marks. (See Fig. 9 or 10)

### Special Note

Which side of T.D.C. (0°) mark to which the engine should be timed varies according to engine rotation. (See Fig. 9 or 10)

### Ignition Coil

When checking out the coil, be certain that the lead from the resistor is connected to the positive (+) terminal and the distributor primary lead is connected to the negative (-) terminal of the coil. Never by-pass the resistor as the coil or distributor may be damaged. (See wiring diagram in rear of manual.)



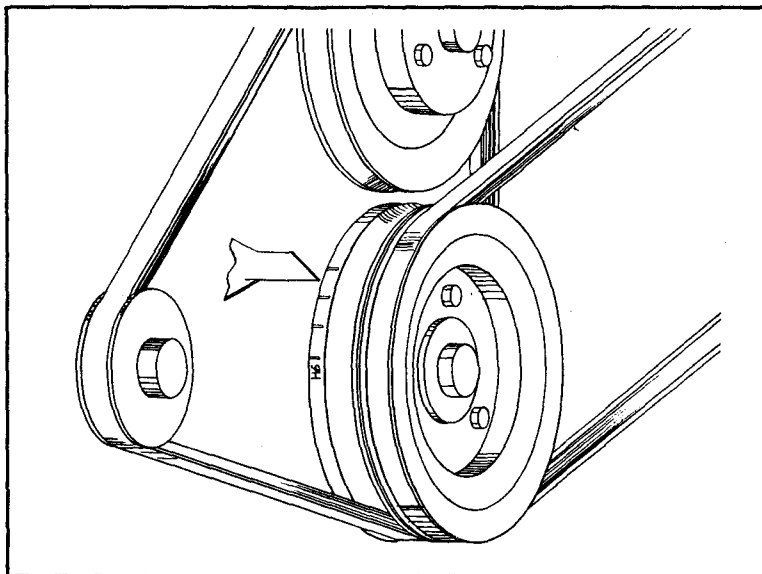

Fig. 9. Left Hand Rotation

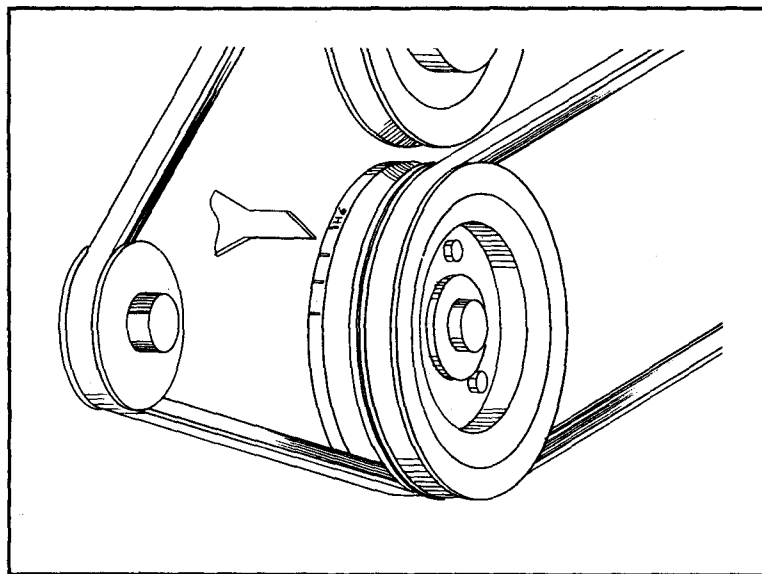

Fig. 10. Right Hand Rotation

## E. Carburetor Adjustment and Repair

### *General Carburetor Repairs*

Flooding, stumble on acceleration and other performance complaints are, in many instances, caused by the presence of dirt, water or other foreign matter in the carburetor. Any major carburetor repairs should be made by **AUTHORIZED DEALERS**.

## F. Fuel Pump

### *Testing – Pressure*

Attach a pressure gauge into fuel line between the fuel pump and carburetor. With the engine idling at 500 R.P.M. the gauge should show a reading of 4-6 lbs. pressure (P.S.I).

Low pressure and/or volume indicates worn diaphragm, clogged ceramic filter, faulty check valves, worn cam lever or cam, air entering the fuel system through a loose fitting between the fuel tank and pump, blocked fuel tank vent line, air leak at sediment bowl gasket, etc.

## G. Valve Adjustment

All engines are equipped with hydraulic valve lifters.

Service and adjustment of the hydraulic lifters should be left to trained mechanics.

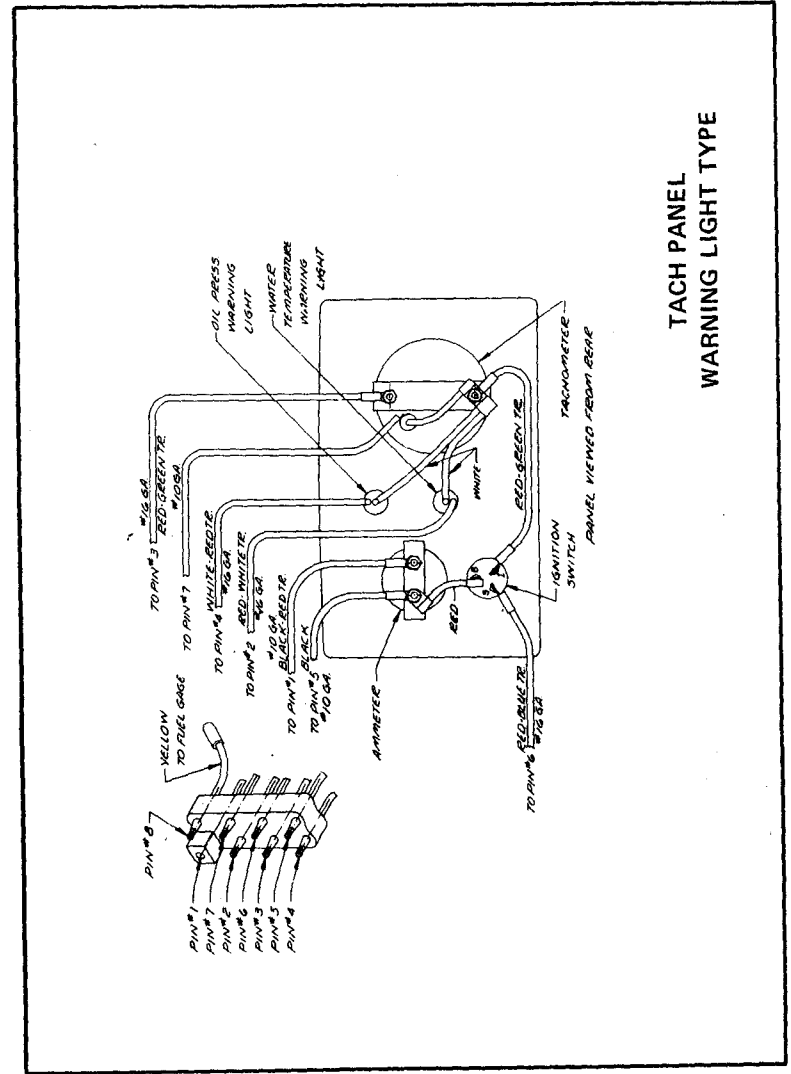
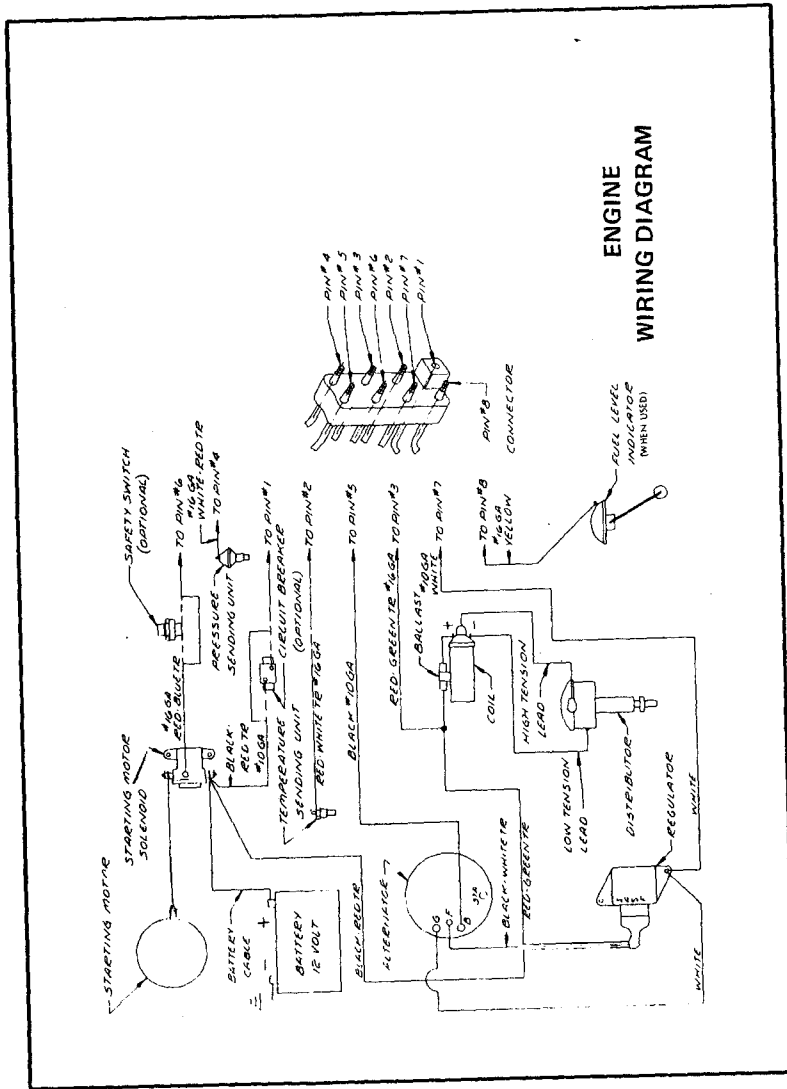

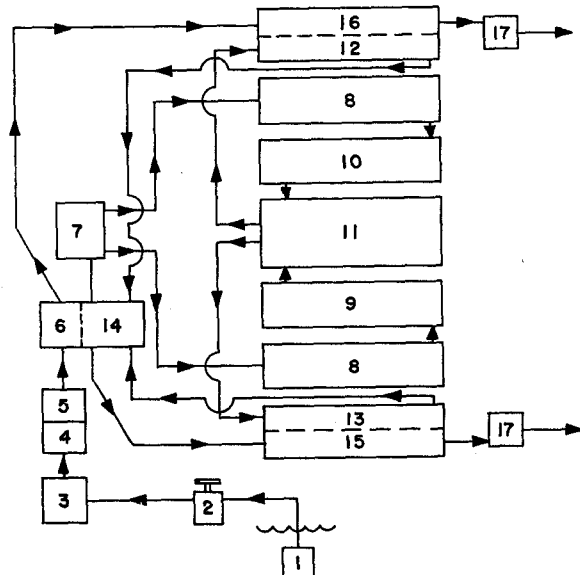

Fig. 11. Raw Water Cooling Circulation Diagram

- |                            |                                    |
|----------------------------|------------------------------------|
| 1. WATER INLET             | 9. LEFT CYLINDER HEAD              |
| 2. SHUT OFF VALVE          | 10. RIGHT CYLINDER HEAD            |
| 3. RAW WATER PUMP          | 11. INTAKE MANIFOLD                |
| 4. ENGINE OIL COOLER       | 12. RIGHT EXHAUST MANIFOLD (LOWER) |
| 5. TRANSMISSION OIL COOLER | 13. LEFT EXHAUST MANIFOLD (LOWER)  |
| 6. PRESSURE RELIEF         | 14. THERMOSTAT                     |
| 7. CENTRIFUGAL WATER PUMP  | 15. LEFT EXHAUST MANIFOLD (UPPER)  |
| 8. CYLINDER BLOCK          | 16. RIGHT EXHAUST MANIFOLD (UPPER) |
|                            | 17. EXHAUST OUTLETS                |

Fig. 11. Raw Water Cooling System Water Circulation

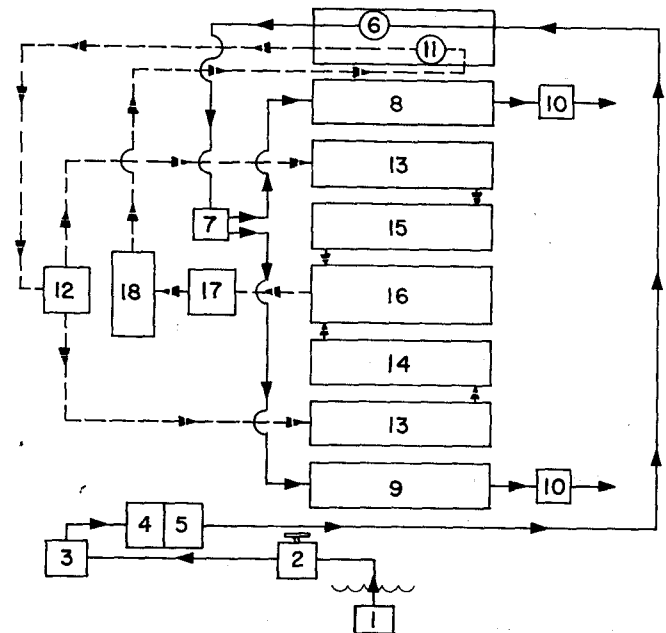

Fig. 12. Fresh Water Cooling System

- |                               |                                  |                    |  |
|-------------------------------|----------------------------------|--------------------|--|
| <u>SEA WATER</u>              |                                  | <u>FRESH WATER</u> |  |
| 1. SEA WATER INLET            | 11. HEAT EXCHANGER (FRESH WATER) |                    |  |
| 2. SHUT OFF VALVE             | 12. CENTRIFUGAL WATER PUMP       |                    |  |
| 3. SEA WATER PUMP             | 13. ENGINE BLOCK                 |                    |  |
| 4. ENGINE OIL COOLER          | 14. LEFT CYLINDER HEAD           |                    |  |
| 5. TRANSMISSION OIL COOLER    | 15. RIGHT CYLINDER HEAD          |                    |  |
| 6. HEAT EXCHANGER (SEA WATER) | 16. INTAKE MANIFOLD              |                    |  |
| 7. WATER TEE                  | 17. THERMOSTAT                   |                    |  |
| 8. RIGHT EXHAUST MANIFOLD     | 18. EXPANSION TANK               |                    |  |
| 9. LEFT EXHAUST MANIFOLD      |                                  |                    |  |
| 10. EXHAUST OUTLETS           |                                  |                    |  |

Fig. 12. Closed Cooling System Water Circulation

## MARINE ENGINE WARRANTY

There are no warranties, expressed or implied, made by either the Distributor or the Dealer of the manufacturer of new marine engines, excepting the manufacturer's warranty against defects in material and workmanship set out below.

The manufacturer reserves the right to make changes in design and make any improvements on its products at any time, without incurring any obligation to make similar changes or add similar improvements on any units previously delivered by it.

The manufacturer warrants its new marine engines (including original equipment placed thereon by the manufacturer) to be free from defects in material or workmanship under normal use and service. The manufacturer's obligation under this warranty is limited to making good at its factory, or at its authorized distributor or dealer, any part or parts of such product which shall be returned to it with transportation charges prepaid, within one year or 500 hours of operation, whichever should occur first, from the date of delivery of said products to the original purchaser and which at examination shall disclose to its satisfaction to have been thus defective. The manufacturer shall not be responsible for non-authorized repair, abuse, neglect, accidents, normal maintenance, freight, routine wear and tear, and normal replacement items.

Obligation under this warranty shall be limited to the replacement of the defective part and the labor to replace same as provided for in its current published Marine Flat Rate Manual. This warranty does not cover parts damaged through abnormal use, of spare parts other than its genuine Marine parts, or through any type of abuse, misuse, accident, or neglect such as not following instructions in their respective Instruction Books or Operating Manuals. Neither shall it apply if modifications have been performed which in any way alter the specifications of the marine engine as originally manufactured.

The warranty does not cover unauthorized labor costs, transportation costs, freight charges, and other charges incurred in the transportation of a unit and the hauling or towing of a boat in or out of the water, and the repairman going to the place where the boat is stored and returning to his office or workshop. Application for adjustment under this warranty must be filled out in its entirety on a factory Application for Adjustment form, be accompanied with all defective parts properly tagged indicating the serial number of the engine or transmission from which they were removed. Labor under this warranty will be based on the manufacturer's current Flat Rate Manual and if the

labor exceeds \$75.00, written authorization must be obtained on Warranty Labor Authorization Form CMC No. 335, from the factory Service Manager or the area Sales and Service Representative. A copy of same must accompany any Application for Adjustment submitted to the Service Department.

This warranty shall not apply to any of the manufacturer's products which are replaced because of normal wear, or products required for routine maintenance of the engine including breaker points, spark plugs, oil and fuel filter elements, water pump impellers, belts and lubricants.

No warranty is implied or valid unless manufacturer's warranty registration has been mailed to the manufacturer within 24 hours of the time the engine is first put into operation by the original owner/operator. A facsimile of the manufacturer's warranty registration form is supplied in this manual and can be detached, filled out in its entirety and mailed to the address on the cover of this manual.

This warranty shall not apply to any product which has been repaired or altered outside of an authorized Service Station, in any way, so as in the judgment of the manufacturer to effect its stability or reliability, or which has been subject to misuse, neglect or accident.

The cost and responsibility of maintaining the product as outlined in the Owner's Operation Manual shall be the obligation of the Owner-Operator. Records of service orders pertaining to maintenance shall be retained and made available to the manufacturer or his authorized representative upon request.

This warranty is expressly in lieu of all other warranties, expressed or implied, including any implied warranty of merchantability or fitness for a particular purpose and for any other obligation or liability on the part of the manufacturer and the manufacturer neither assumes nor authorizes any person to assume for it any other liability in connection with such marine engine, transmission and accessories.

### THE OWNER-OPERATOR'S OBLIGATION TO HIMSELF

- A. Because of the various ways in which marine engines are distributed and ultimately sold to owner-operators, the company is not likely to know you personally. In order to forestall misunderstandings, it is in your interest to tell the company about your purchase by completing and returning your new owner's Registry Card. Because this step will protect you, we insist that you take this precautionary step within ten (10) days following the date of your purchase. Unless you do so, the company may, at its discretion, disallow any future warranty claim.

B. Apart from getting "on record" with the company, there are several steps which you should observe prior to taking delivery of the engine:

1. make sure the engine has been selected for proper service. This is not the engine maker's responsibility;
2. make sure the selling or installing dealer has checked all adjustments, such as ignition timing, routing of wires, tightness of hose clamps, throttle adjustment and shift controls, etc., before you accept delivery;
3. check out your parts list on expendable items which are not warranted, such as oil filters, fuel filters, spark plugs, lubrication oils, points, condensers, engine tuning, etc., which are the selling dealer's responsibility;
4. make sure your installed engine has been checked out on performance prior to delivery; the company will not reimburse or accept cost for transportation, hauling a boat in or out of the water, storage charges or the expenses of repairmen traveling to boat location and return;
5. don't try to ignore trouble; the company reserves the right to inspect engines both before and after completion of any warranty work, and to discuss the satisfaction of work performed with the owner-operator;
6. give your engine a chance to prove itself in home waters; the company reserves the right to reimburse all warranty claims at the flat rate labor cost currently expressed by our Flat Rate Labor Manual.
7. check to be sure that all replacement parts are genuine company parts or approved for use by Thermo Electron Engine Corp.;
8. become completely familiar with the guaranteed performance characteristics of your engine, and master the details of maintenance and operating instructions; your marine engine cannot be kept or operated in an off-hand manner, and to do so will in the long run only cost you money; if you need assistance in respect of learning how to operate and maintain your engine, feel free to contact Thermo Electron Engine Corp.

AUGUST 8, 2005

DISTCAP

- NAPA MA8

ROTOR

- NAPA AL65

PLUGS

- AUTOLITE 45