

3 SECT. WEST SCREEN WALL
A-12 Scale 1"=1'-0" SCREEN-WEST-SECT-12

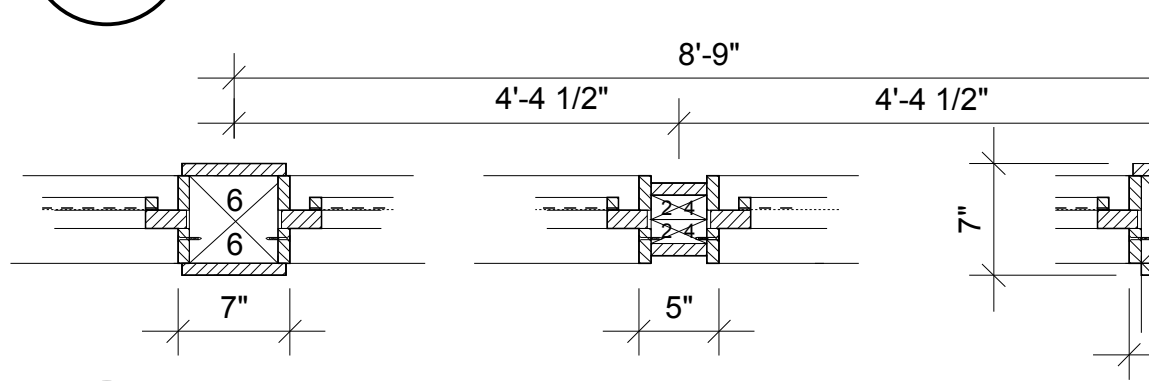

4 SECT. NORTH & SOUTH SCREEN WALL
A-12 Scale 1"=1'-0" SCREEN-N-S-SECT-12



5 SCREEN POST DETAIL
A-12 Scale 1"=1'-0" POST-DETS

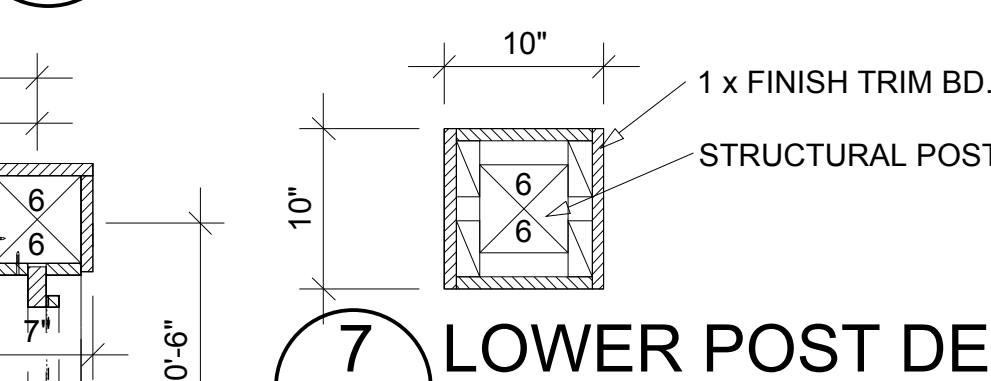

7 LOWER POST DET.
A-12 Scale 1"=1'-0"

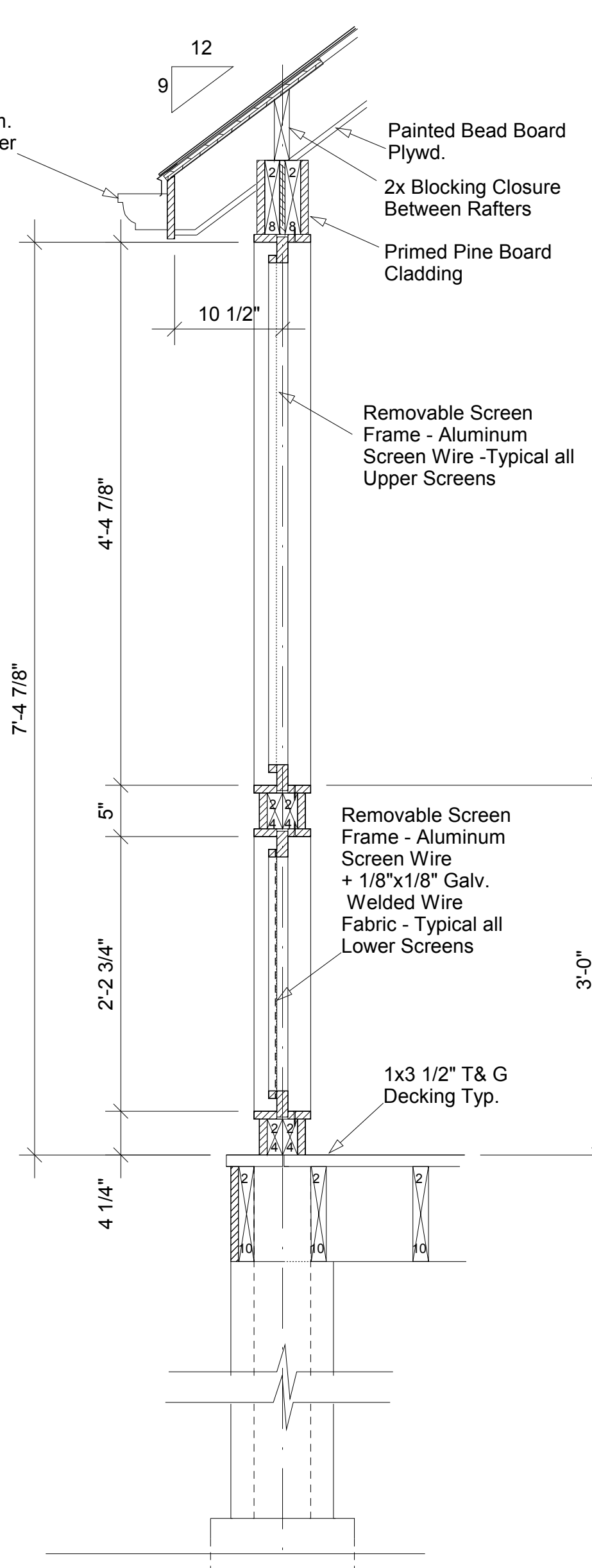

6 SCREEN-PORCH DECK DETAIL
A-12 Scale 1"=1'-0" BLDG-SECT_E-W-SECT-2

1 SCREENED PORCH - SECTION
A-12 Scale 1/4"=1'-0" SCREEN-PORCH-SECT

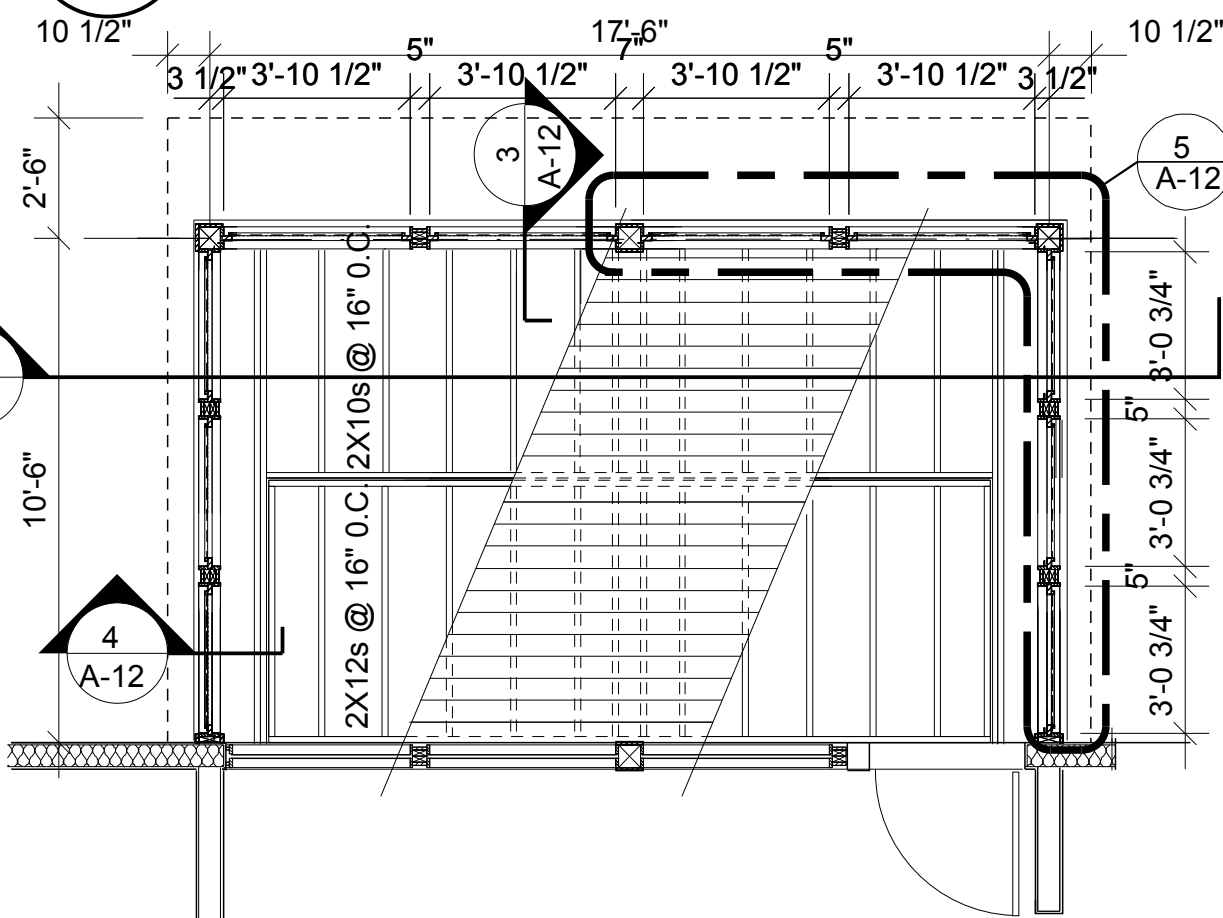

2 SCREENED PORCH - PLAN
A-12 Scale 1/4"=1'-0" SCREEN-PORCH-PLN

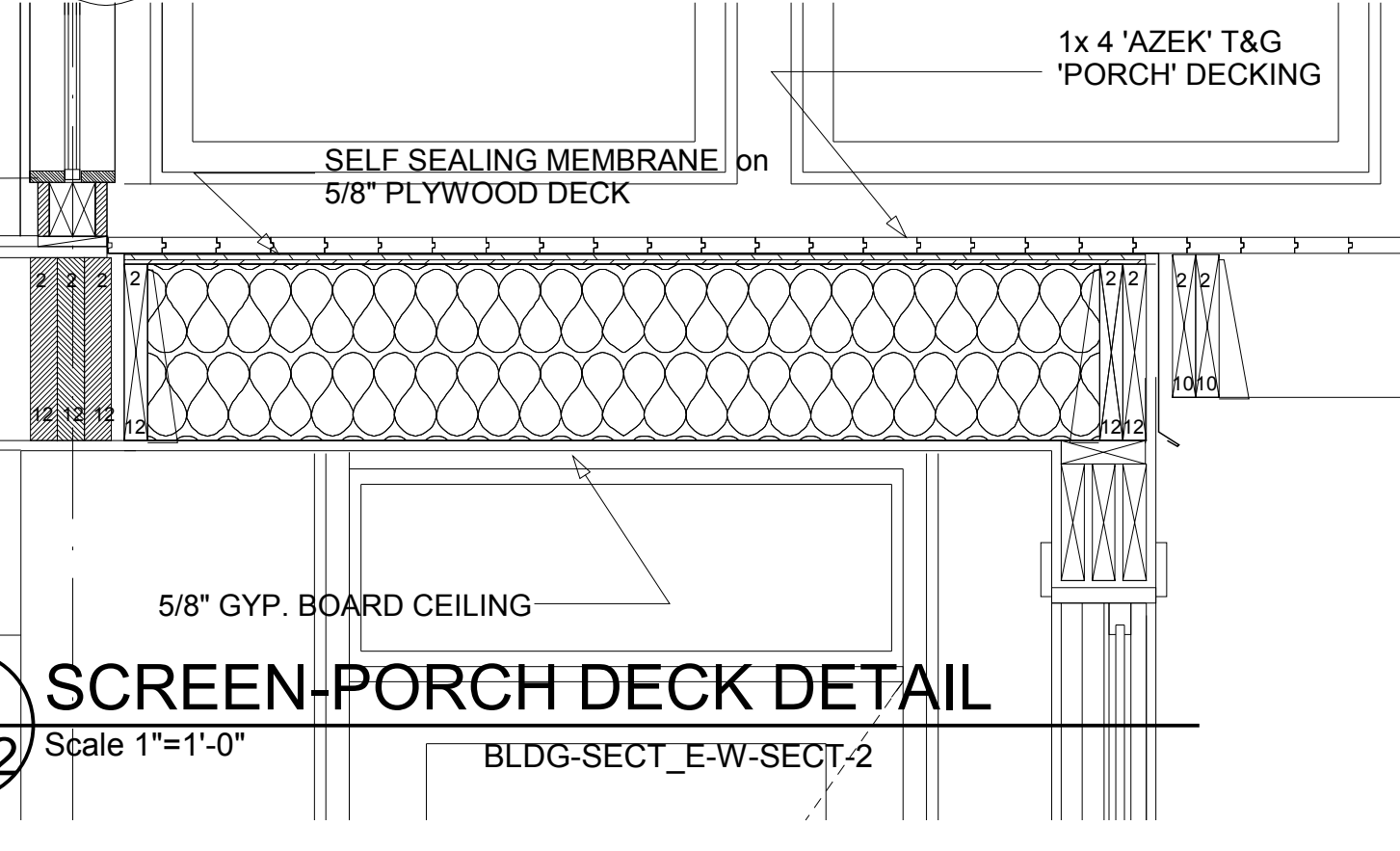

Expires 11/30/2018

MacLaren Residence

51 FAIRVIEW LANE
SPRINGFIELD IL

Architect:
Robert E. Edmonds
7158 Waterman Ave
St. Louis, MO 63130
314-324-9333
reedmonds@yahoo.com

A-12
SCREEN-PORCH DETS